

UPLUS

NEW TECHNOLOGY BATTERY



Battery Type	Voltage (V)	Capacity (Ah)	CCA-SAE @ (18°C)	Dimensions - Millimeters (±2mm)			Dimensions - Inches (±2mm)			Assembly Figure (As Per Cover Polarity)	Terminal Type	Gross Weight	
		Ah	A	L	W	H	L	W	H			Kg	Lbs
EBZ4.5-3	12	4	50	113	70	85	4 7/16	2 3/4	3 1/2	[-][][][]+	A	1.54	3.4
EBZ7-3-2	12	6	90	113	70	105	4 7/16	2 3/4	4 1/8	[-][][][]+	A	2.13	4.7
EBZ6.5-3	12	6.5	105	113	70	121	4 7/16	2 3/4	4 6/8	[-][][][]+	A	2.34	5.2
EBZ8-3	12	7	95	113	70	130	4 7/16	2 3/4	5	[-][][][]+	A	2.35	5.2
EB9-4	12	8	120	150	87	105	5 14/16	3 2/4	4	+[][][]-	A	3.04	/

Leoch Battery Pte Ltd Sales Office address : 1 Tech Park Crescent, Singapore 638131
 Marstech Systems Pte Ltd (authorised distributor) address : 1046 Eunos Ave 5, #01-133Singapore 409746

EBZ4.5-3 [12V4Ah]

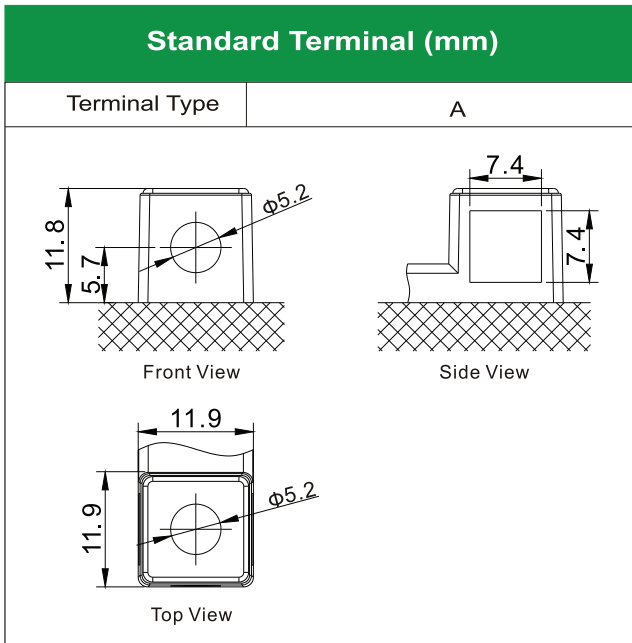
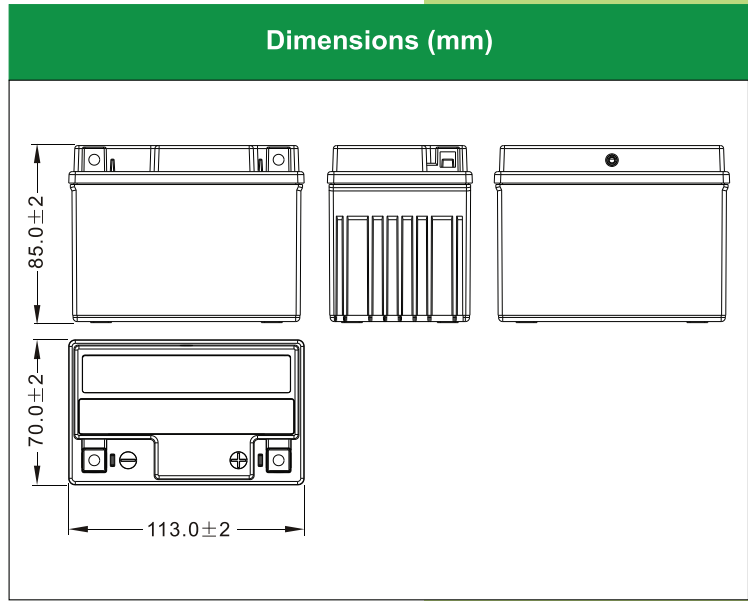

Physical Specification

Nominal Voltage	12V	
Nominal Capacity (10HR)	4Ah	
Dimension	Length	113 ± 2mm (4.45 inches)
	Width	70 ± 2mm (2.76 inches)
	Container Height	85 ± 2mm (3.35 inches)
	Total Height (with Terminal)	85 ± 2mm (3.35 inches)
Weight	Battery(with acid): Approx 1.52kg (3.35lbs)	

- * Sealed and non-spillable AGM battery
- * Maintenance-free
- * Powerful 55 cold cranking amps (-18°C, SAE Standard)
- * Shipped pre-charged and ready to install
- * Replaces none battery

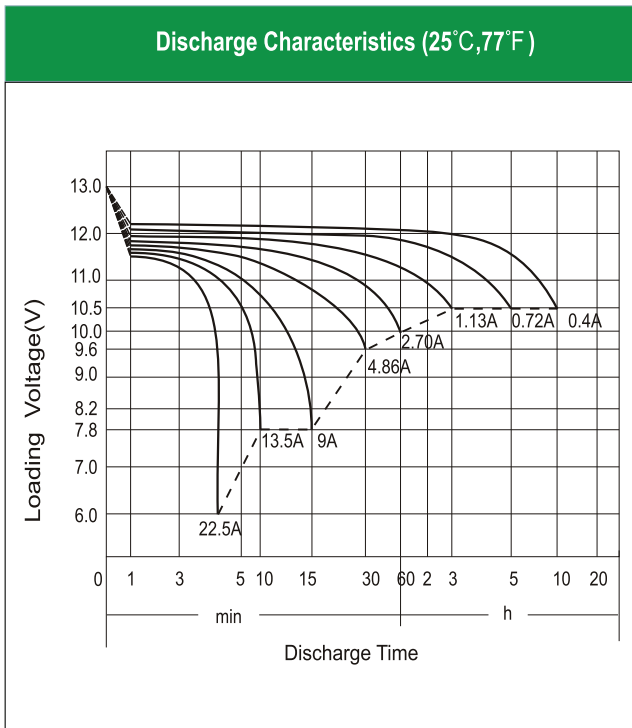

Electrical Specification

Rated Capacity	10 hour rate (0.45 A)	4.50Ah
	5 hour rate (0.72 A)	3.60Ah
	2 hour rate (1.58 A)	3.16Ah
	1 hour rate (2.70 A)	2.70Ah
	0.5 hour rate (4.86 A)	2.43Ah
Capacity affected by Temperature	40 °C (104 °F)	106%
	25 °C (77 °F)	100%
	0 °C (32 °F)	86%
	-15 °C (5 °F)	65%
Charging Methods	Full Charge	Constant-Voltage Charge: Initial charging current: less than 1.05A Voltage: 14.40 V ~ 15.00 V at 25 °C (77 °F) Charging time: 15 ~18h Constant-Current Charge: Charging current: 0.1C ₁₀ =0.45A, when charging voltage up to 14.40V, continue to charge 4h
	Floating Charge	No limit on Initial charging current Voltage: 13.50 V ~ 13.80 V at 25 °C (77 °F)

*Values are subject to variation of +/- 5% in normal manufacturing processes.
*Technical specifications and the product line above could be changed without prior notice.

EBZ6.5-3 [12V6.5Ah]

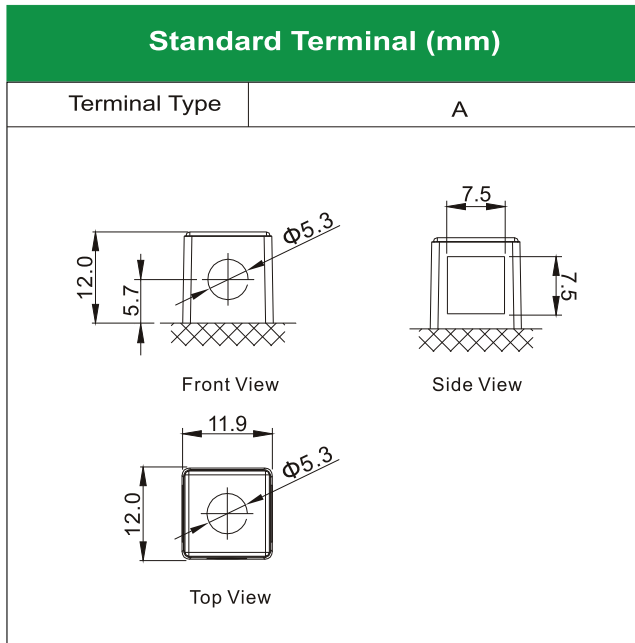
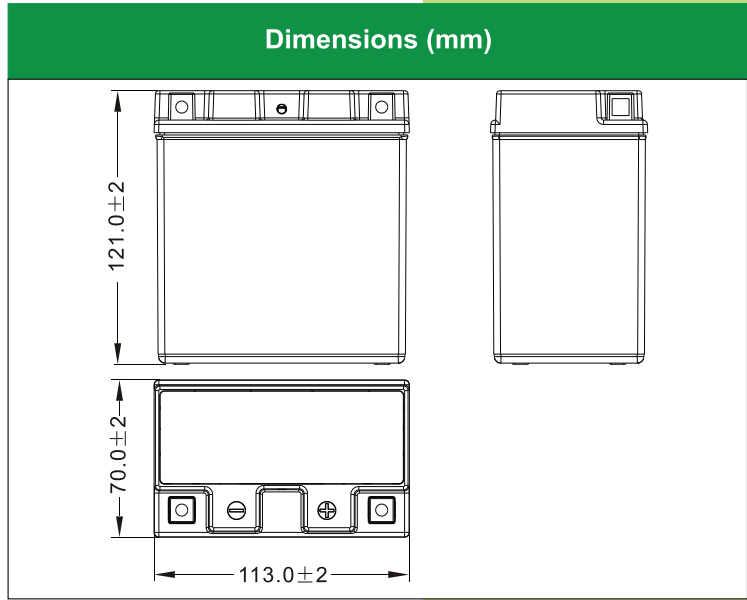

Physical Specification

Nominal Voltage	12V	
Nominal Capacity (10HR)	6.5Ah	
Dimension	Length	113 ± 2mm (4.45 inches)
	Width	70 ± 2mm (2.76 inches)
	Container Height	121 ± 2mm (4.76 inches)
	Total Height (with Terminal)	121 ± 2mm (4.76 inches)
Weight	Battery(with acid): Approx 2.34kg (5.16lbs)	

- * Sealed and non-spillable AGM battery
- * Maintenance-free
- * Powerful 105 cold cranking amps (-18°C, SAE Standard)
- * Shipped pre-charged and ready to install
- * Replaces none battery

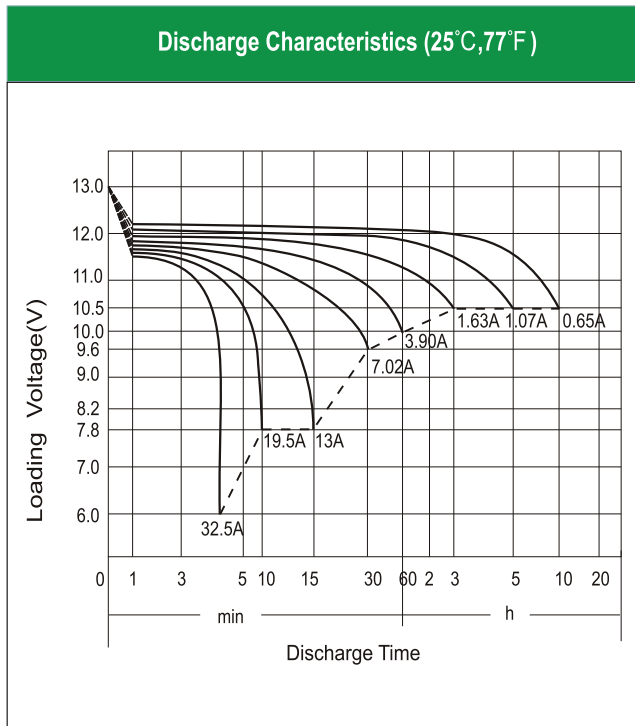

Electrical Specification

Rated Capacity	10 hour rate (0.65A)	6.50Ah
	5 hour rate (1.07 A)	5.33Ah
	2 hour rate (2.28 A)	4.55Ah
	1 hour rate (3.90 A)	3.90Ah
	0.5 hour rate (7.02 A)	3.51Ah
Capacity affected by Temperature	40 °C (104 °F)	106%
	25 °C (77 °F)	100%
	0 °C (32 °F)	86%
	-15 °C (5 °F)	65%
Charging Methods	Full Charge	Constant-Voltage Charge: Initial charging current: less than 1.95A Voltage: 14.40 V ~ 15.00 V at 25 °C (77 °F) Charging time: 15 ~18h Constant-Current Charge: Charging current: 0.1C ₁₀ =0.65A, when charging voltage up to 14.40V, continue to charge 4h
	Floating Charge	No limit on Initial charging current Voltage: 13.50 V ~ 13.80 V at 25 °C (77 °F)

*Values are subject to variation of +/- 5% in normal manufacturing processes.
 *Technical specifications and the product line above could be changed without prior notice.

EBZ7-3-2 [12V6Ah]

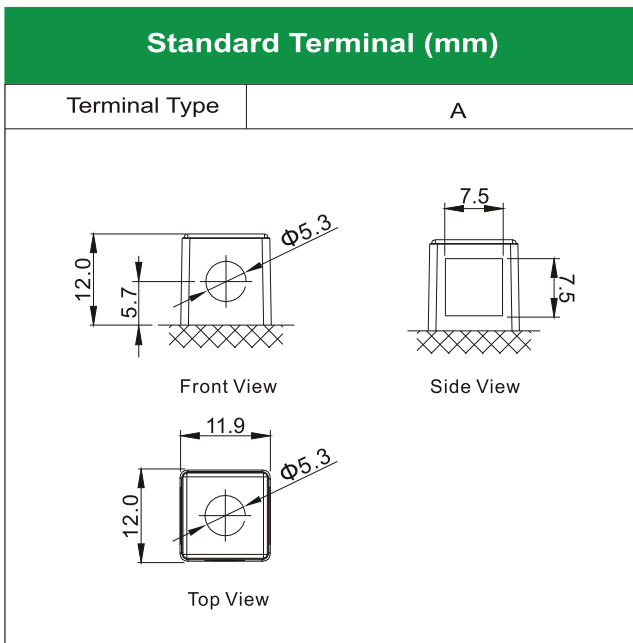
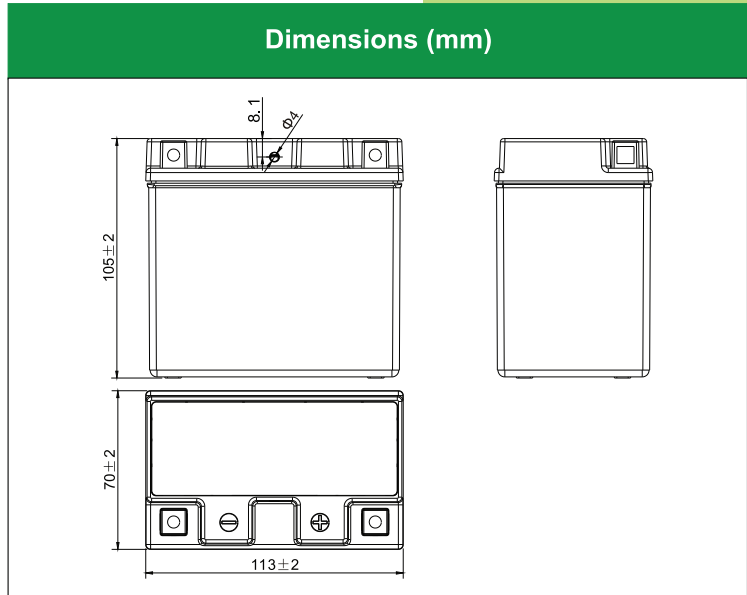

Physical Specification

Nominal Voltage	12V	
Nominal Capacity (10HR)	6Ah	
Dimension	Length	113 ± 2mm (4.45 inches)
	Width	70 ± 2mm (2.76 inches)
	Container Height	105 ± 2mm (4.13 inches)
	Total Height (with Terminal)	105 ± 2mm (4.13 inches)
Weight	Battery(with acid): Approx 2.13kg (4.70lbs)	

- * Sealed and non-spillable AGM battery
- * Maintenance-free
- * Powerful 90 cold cranking amps (-18°C, SAE Standard)
- * Shipped pre-charged and ready to install
- * Replaces EBZ7L-BS battery

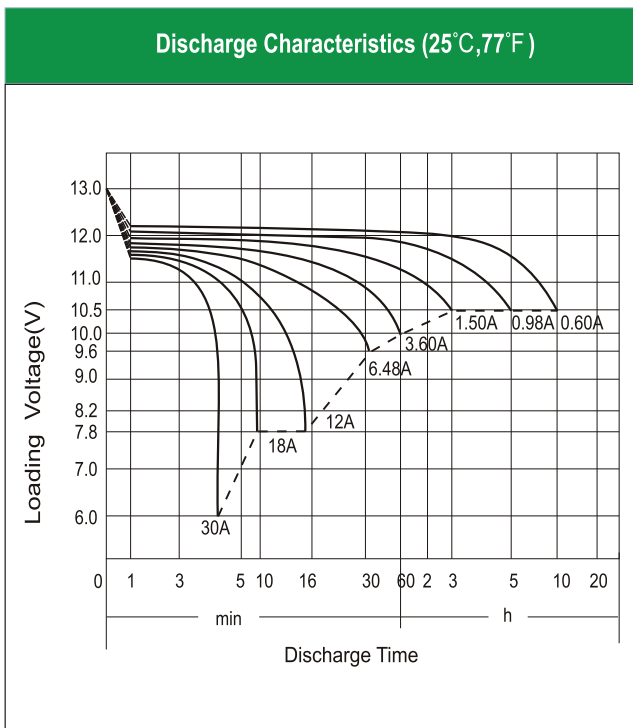

Electrical Specification

Rated Capacity	10 hour rate (0.60 A)	6.00Ah
	5 hour rate (0.98 A)	4.92Ah
	2 hour rate (2.10 A)	4.20Ah
	1 hour rate (3.60 A)	3.60Ah
	0.5 hour rate (6.48 A)	3.24Ah
Capacity affected by Temperature	40 °C (104 °F)	106%
	25 °C (77 °F)	100%
	0 °C (32 °F)	86%
	-15 °C (5 °F)	65%
Charging Methods	Full Charge	Constant-Voltage Charge: Initial charging current: less than 1.8A Voltage: 14.40 V ~ 15.00 V at 25 °C (77 °F) Charging time: 15 ~18h Constant-Current Charge: Charging current: 0.1C ₁₀ =0.60A, when charging voltage up to 14.40V, continue to charge 4h
	Floating Charge	No limit on Initial charging current Voltage: 13.50 V ~ 13.80 V at 25 °C (77 °F)

*Values are subject to variation of +/- 5% in normal manufacturing processes.
*Technical specifications and the product line above could be changed without prior notice.

EBZ8-3 [12V7Ah]

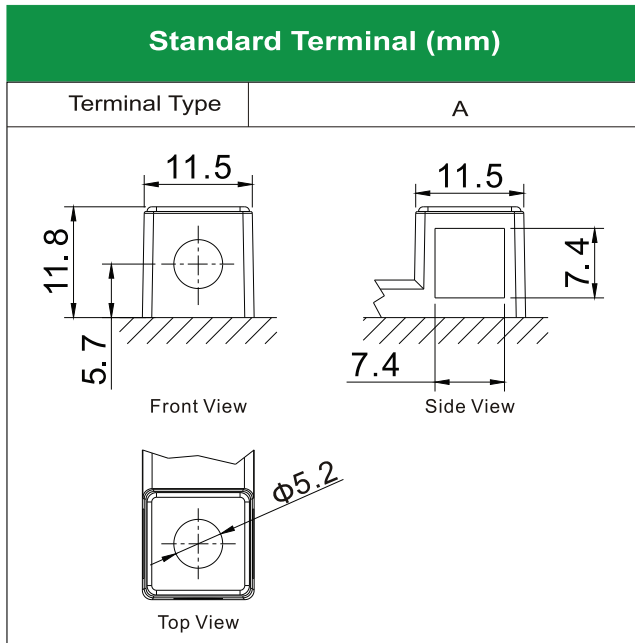
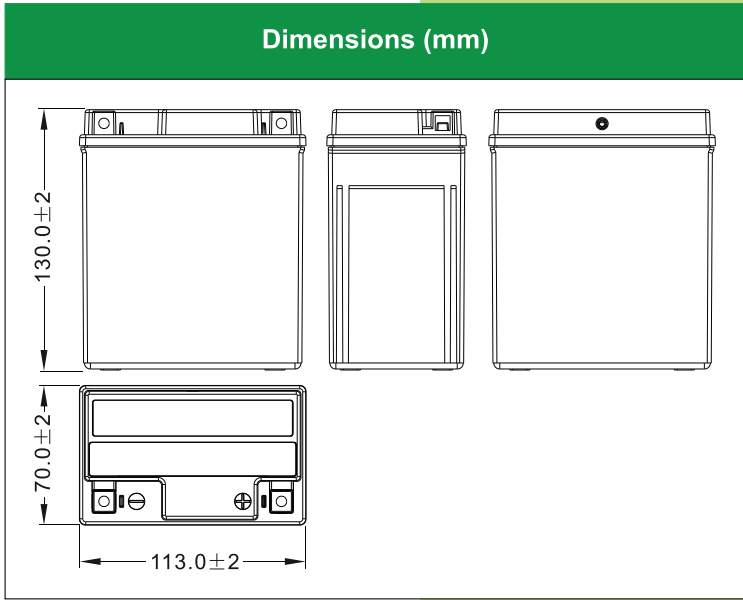

Physical Specification

Nominal Voltage	12V	
Nominal Capacity (10HR)	7Ah	
Dimension	Length	113 ± 2mm (4.45 inches)
	Width	70 ± 2mm (2.76 inches)
	Container Height	130 ± 2mm (5.12 inches)
	Total Height (with Terminal)	130 ± 2mm (5.12 inches)
Weight	Battery(with acid): Approx 2.35kg (5.18lbs)	

- * Sealed and non-spillable AGM battery
- * Maintenance-free
- * Powerful 95 cold cranking amps (-18°C, SAE Standard)
- * Shipped pre-charged and ready to install
- * Replaces none battery

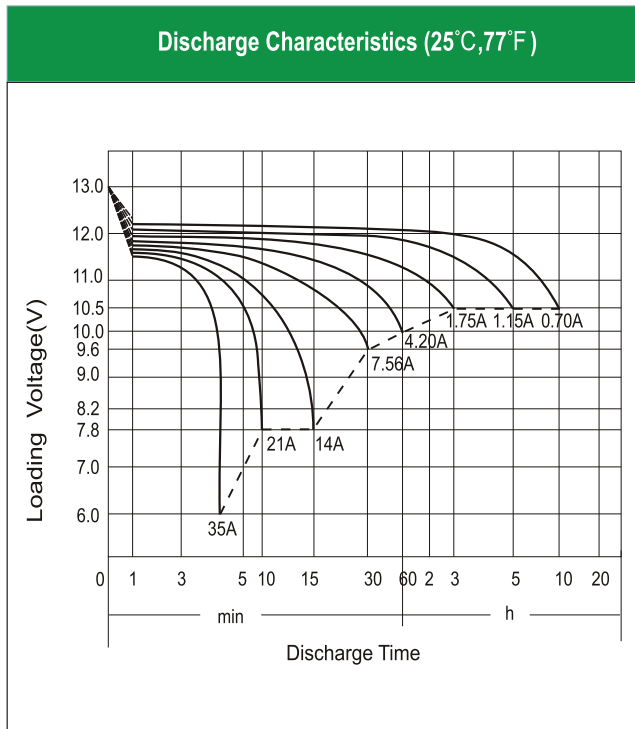

Electrical Specification

Rated Capacity	10 hour rate (0.70 A)	7.00Ah
	5 hour rate (1.15 A)	5.74Ah
	2 hour rate (2.45 A)	4.90Ah
	1 hour rate (4.20 A)	4.20Ah
	0.5 hour rate (7.56 A)	3.78Ah
Capacity affected by Temperature	40 °C (104 °F)	106%
	25 °C (77 °F)	100%
	0 °C (32 °F)	86%
	-15 °C (5 °F)	65%
Charging Methods	Full Charge	Constant-Voltage Charge: Initial charging current: less than 2.1A Voltage: 14.40 V ~ 15.00 V at 25 °C (77 °F) Charging time: 15 ~18h Constant-Current Charge: Charging current: 0.1C ₁₀ =0.70A, when charging voltage up to 14.40V, continue to charge 4h
	Floating Charge	No limit on Initial charging current Voltage: 13.50 V ~ 13.80 V at 25 °C (77 °F)

*Values are subject to variation of +/- 5% in normal manufacturing processes.
 *Technical specifications and the product line above could be changed without prior notice.

EB9-4 (12V8Ah)

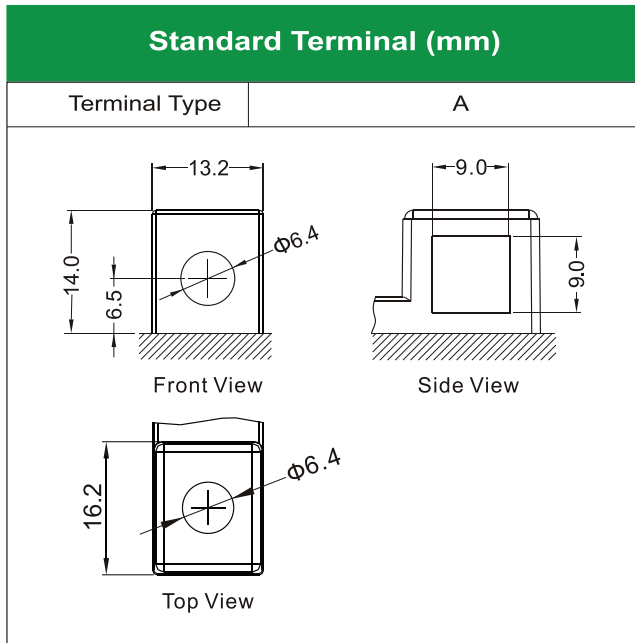
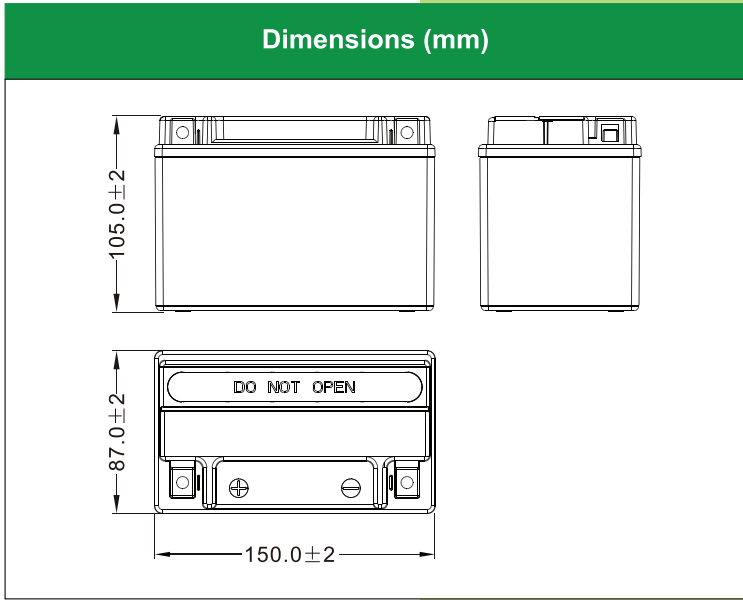
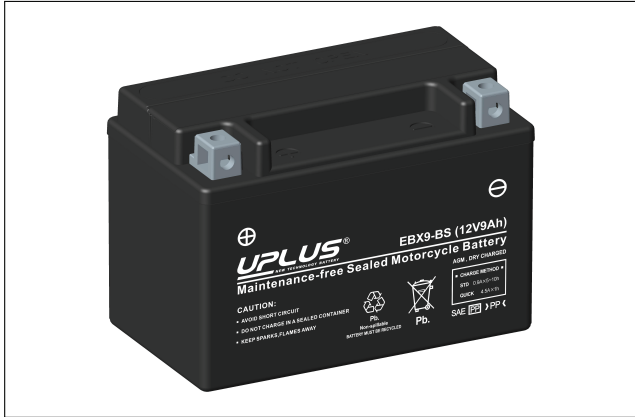

Physical Specification

Nominal Voltage	12V	
Nominal Capacity (10HR)	8Ah	
Dimension	Length	150 ± 2mm (5.875 inches)
	Width	87 ± 2mm (3.5 inches)
	Container Height	105 ± 2mm (4 inches)
	Total Height (with Terminal)	105 ± 2mm (4 inches)
Weight	Battery(with acid): Approx 3.04kg (6.70lbs)	

- * Sealed AGM battery
- * Fresh Pack, Maintenance Free
- * Powerful 120 cold cranking amps(-18°C, SAE Standard)
- * Rest after filling acid
- * Maximum tilt angle for installation: 25°

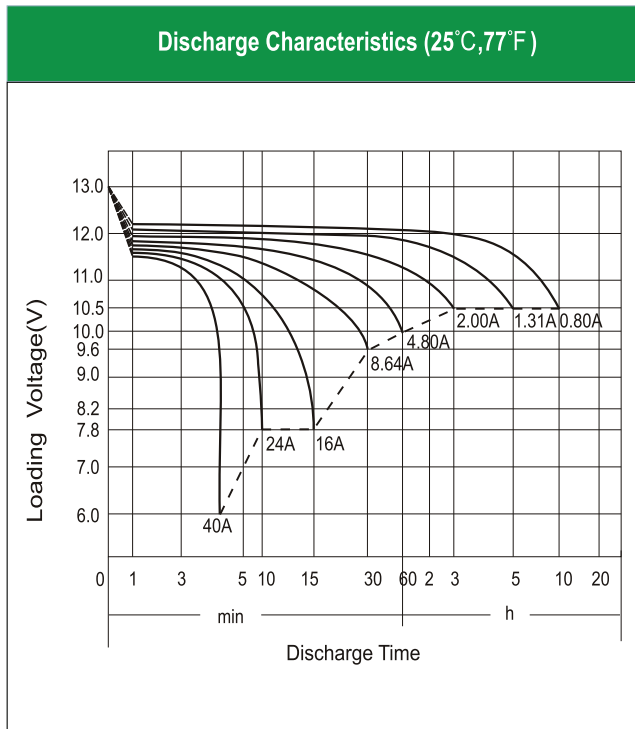

Electrical Specification

Rated Capacity	10 hour rate (0.80 A)	8.00Ah
	5 hour rate (1.31 A)	6.56Ah
	2 hour rate (2.80 A)	5.60Ah
	1 hour rate (4.80 A)	4.80Ah
	0.5 hour rate (8.64 A)	4.32Ah
Capacity affected by Temperature	40 °C (104 °F)	106%
	25 °C (77 °F)	100%
	0 °C (32 °F)	86%
	-15 °C (5 °F)	65%
Charging Methods	Full Charge	Constant-Voltage Charge: Initial charging current: less than 2.4A Voltage: 14.40 V ~ 15.00 V at 25 °C (77 °F) Charging time: 15 ~18h Constant-Current Charge: Charging current: 0.1C ₁₀ =0.80A, when charging voltage up to 14.40V, continue to charge 4h
	Floating Charge	No limit on Initial charging current Voltage: 13.50 V ~ 13.80 V at 25 °C (77 °F)

*Values are subject to variation of +/- 5% in normal manufacturing processes.
*Technical specifications and the product line above could be changed without prior notice.